

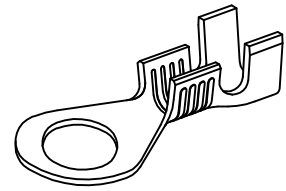

PARÇA KODU PART CODE	PARÇA ADI PART NAME	s ÖLÇÜSÜ (KALINLIK) s MEASURE (THICKNESS)	Malzeme Material	Kaplama Coating
MS 2425 DP	4 NO KABLO UÇ Ø6.2 =DP=	0.38±0.05	(CuZn30) Pirinç / Brass	—
MS 2425 RP	4 NO KABLO UÇ Ø6.2 =RP=	0.38±0.05	(CuZn30) Pirinç / Brass	—
MS 2425.50 DP	4 NO KABLO UÇ Ø6.2 =DP=	0.50±0.05	(CuZn30) Pirinç / Brass	—
MS 2425.50 RP	4 NO KABLO UÇ Ø6.2 =RP=	0.50±0.05	(CuZn30) Pirinç / Brass	—
TŞ 2425.60 DP	4 NO KABLO UÇ Ø6.2 =DP=	0.60±0.05	(CuZn30) Pirinç / Brass	—
TŞ 2425.60 RP	4 NO KABLO UÇ Ø6.2 =RP=	0.60±0.05	(CuZn30) Pirinç / Brass	—
TŞ 2425.60 RPK	4 NO KABLO UÇ Ø6.2 =RPK=	0.60±0.05	(CuZn30) Pirinç / Brass	Kalay / Sn (3-5µ)
TŞ 2425.60 RÇN	4 NO KABLO UÇ Ø6.2 =RÇN=	0.60±0.05	Nikel kaplı çelik / Nickel plated steel	Nikel / Ni (≥1.5µ)
TŞ 2425.70 RP	4 NO KABLO UÇ Ø6.2 =RP=	0.70±0.05	(CuZn30) Pirinç / Brass	—

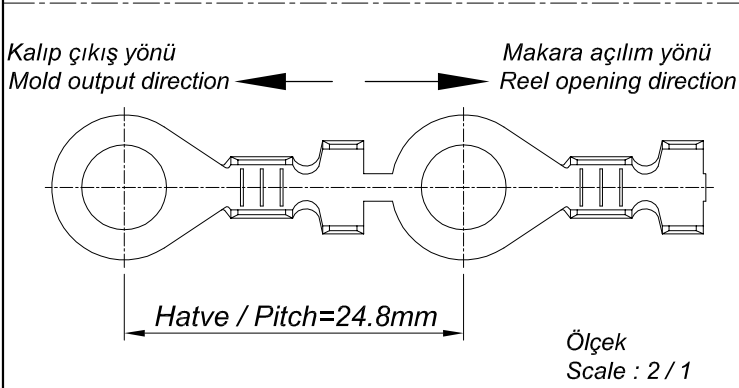
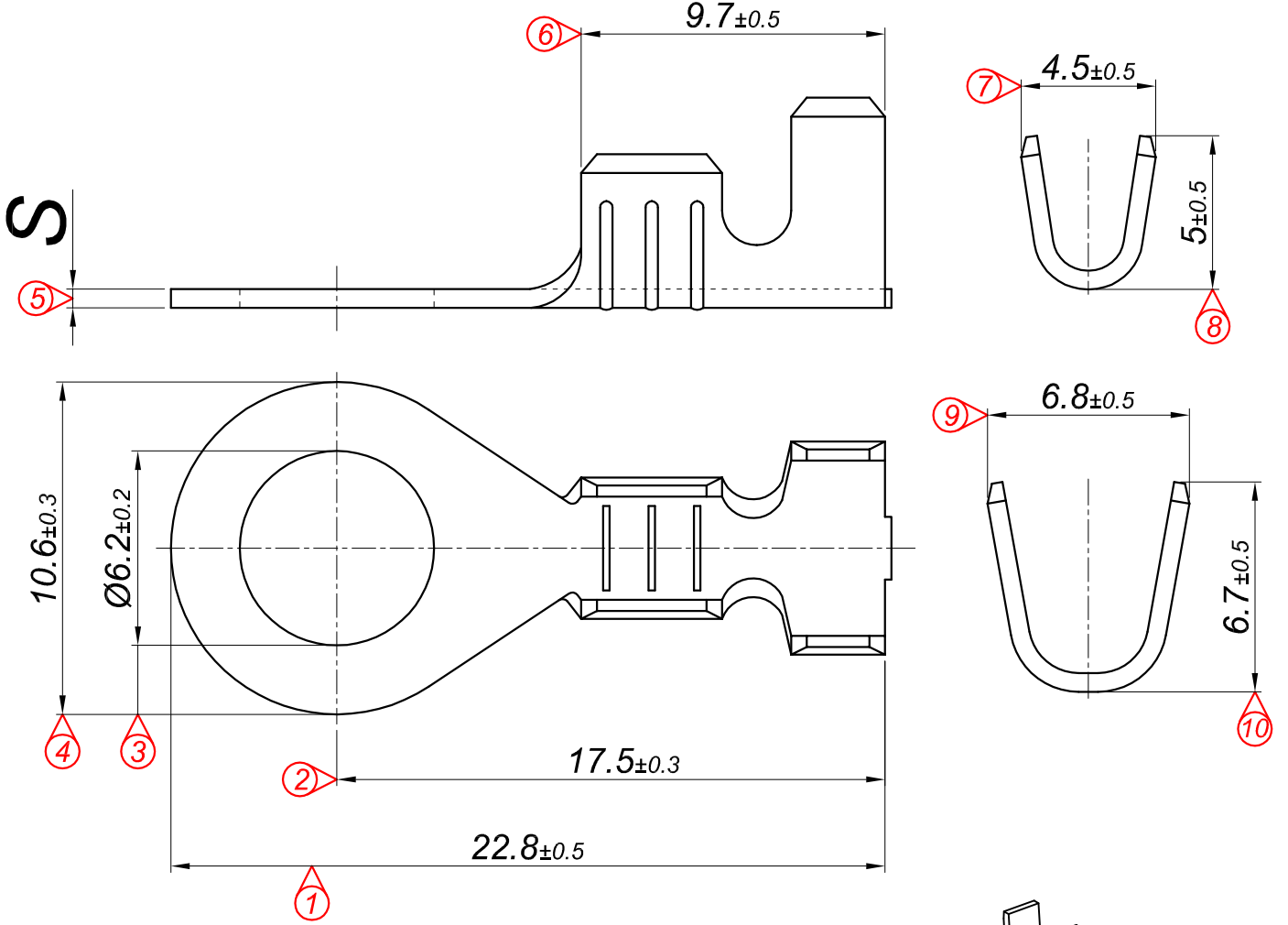

Perspektif
Perspective

Kablo Kesiti
Wire Section : 2.50 - 4 mm²

Resim üzerinden ölçü almayınız
do not measure on drawing

Tarih / Date	25.07.2013	İmza /Signature	Ölçek /Scale		
Çizen / Desing	M.Yağcı		5 / 1		
Onay / Approval	S.Gölcük		No	Değişiklik / Revision	Tarih/Date
	Parça Adı: Part Name	4 NO KABLO UCU Ø6.2		Parça Kodu: Part Code	TŞ 2425